

Axia

INSTRUCTION MANUAL

BUILT-IN HOB

Content

1. PACKING LIST.....	3
2. USAGE PRECAUTIONS.....	3
3. SAFETY PRECAUTIONS.....	4
4. PACKAGE DISPOSAL INSTRUCTIONS.....	4
5. INSTRUCTIONS FOR THE INSTALLER	5
6. INSTRUCTIONS FOR THE USER.....	7
7. CLEANING AND MAINTENANCE.....	9
8. TROUBLESHOOTING.....	10
9. PRODUCT SPECIFICATION.....	11-12

THESE INSTRUCTIONS ARE VALID ONLY FOR END USER COUNTRIES WHOSE IDENTIFICATION SYMBOLS(THESE COUNTRIES ABBREVIATION CODE)APPEAR ON THE CARTON LABLE.THE INSTRUCTIONS MUST BE TRANSLATED INTO OFFICIAL LANGUAGE ACCORDING TO THE COUNTRIES OF DESTINATION AND BE VALID IN THESE COUNTRIES.



INSTRUCTIONS FOR THE USER: these provide recommendations for use, a description of the controls and the correct procedures for cleaning and maintaining the appliance



INSTRUCTIONS FOR THE INSTALLER: these are intended for the qualified engineer who is to install, commission and test the appliance

Please pay attention to the amount of accessories, and make sure there is no scarcity or shatters

- ① Please contact with the dealer when our company or the dealer is responsible for the above carelessness.
- ② Please contact the nearest service center engaged by special arrangement if the user should bear the responsibility.

1. [Packing List]

- (1) Built-in gas hobone
- (2) Metal circle to fastening rubber tubeone
- (3) User's handbookone

2.USAGE PRECAUTIONS



This manual is an integral part of the appliance. Take good care of it and keep it to hand throughout the hob's life cycle.

We urge you to read this manual and all the information it contains carefully before using the appliance.

Installation must be carried out by qualified staff in compliance with the relevant regulations. This appliance is intended for household use and complies with the EEC directives currently in force. The appliance is built to provide the following function: cooking and heating foods; all other uses are to be considered improperly.

The manufacturer declines all liability for uses other than those stated above.



This appliance is not connected to a combustion products evacuation device. It shall be installed and connected in accordance with current installation regulations. Particular attention shall be given to the relevant requirements regarding ventilation.



Prior to installation, ensure that the local distribution conditions (nature of the gas and gas pressure) and the adjustment of the appliance are compatible.

The appliance belongs to category III that are designed for use with gases of the three families.



Never use this appliance for heating rooms.

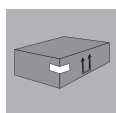

Never use packing residues unattended in the home. Separate the various waste packaging materials by type and consign them to the nearest separate disposal centre.



This appliance is marked according to the European directive 2002/96/ec on waste electrical and electronic equipment (WEEE). This guideline is the frame of European-wide validity of return and recycling on waste electrical and electronic equipment.



Never obstruct the openings and slits provided for ventilation and heat dispersal.



The nameplate with the technical data, serial number and mark are in a visible position underneath the casing. The nameplate must never be removed.

3. SAFETY PRECAUTIONS



The appliance is intended for use by adults. Keep children at a safe distance and never allow them to play with it.

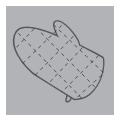

The appliance becomes very hot during use. Oven gloves should always be worn.



Always check that the control knobs are turned to off after each use



The manufacturer declines all responsibility for injury or damage caused by failure to comply with the above regulations or deriving from tampering with even just one part of the appliance and the use of non-original spare parts.

4. PACKAGE DISPOSAL INSTRUCTIONS –

ENVIRONMENT POLICY

Our products are only packaged using non-pollutant, environment-friendly, recyclable materials. We urge you to cooperate by disposing of the packaging properly. Contact your local dealer or the competent local organizations for the addresses of collection, recycling and disposal facilities.

Never leave all or part of the packaging lying around. Packaging parts, and especially plastic bags, may represent a suffocation hazard for children.

Your old appliance must also be disposed of properly. Important: deliver the appliance to your local organization authorized to collect scrapped appliances. Proper disposal allows the intelligent recovery of valuable materials.

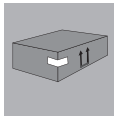

Never leave packaging residues unattended in the home. Separate waste packaging materials by type and consign them to the nearest separate disposal centre.

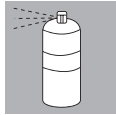

The inside of the appliance should be cleaned to remove all manufacturing residues. For further information, see point “CLEANING AND MAINTENANCE”.

5. INSTRUCTIONS FOR THE INSTALLER



The following operation requires building and/or carpentry work so must be carried out by a competent tradesman.

Installation can be carried out on various materials such as masonry, metal, solid wood or plastic laminated wood, as long as they are heat-resistant($T90^{\circ}\text{C}$)

5.1 Attachment to support structure, traditional built-in model

Create an opening with the dimensions shown in the figure 1 or refer to the table-board cutting template which in the carton. In the work surface, observing a minimum distance of 50mm from the rear edge. This appliance can be installed next to walls that are higher than the work surface, as long as the distance “X” is kept between the appliance and the wall, as shown in the figure, to avoid damage from overheating. Make sure there is a minimum of 750mm between the gas rings and any shelf that may be installed directly above them(figure 2) .

figure 1

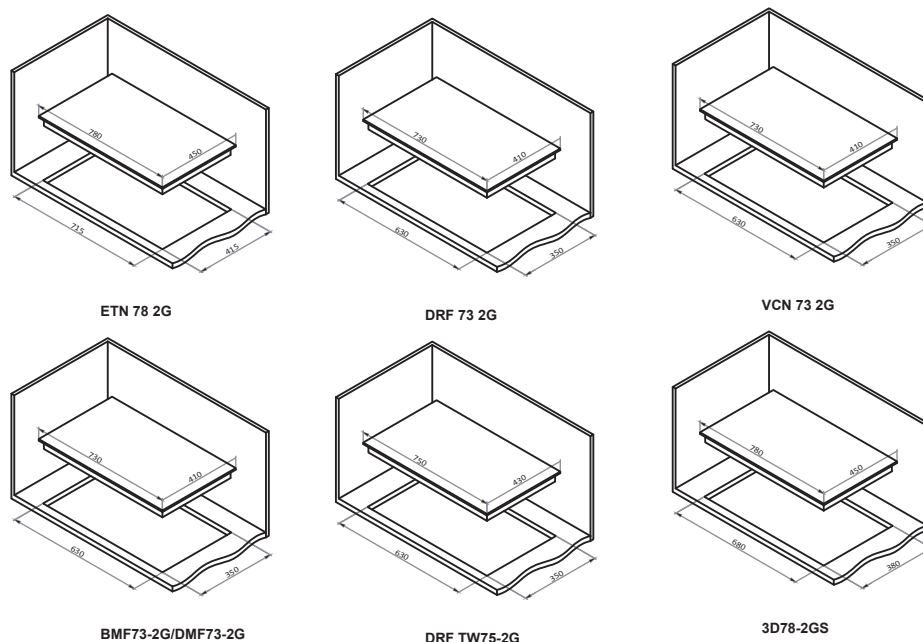

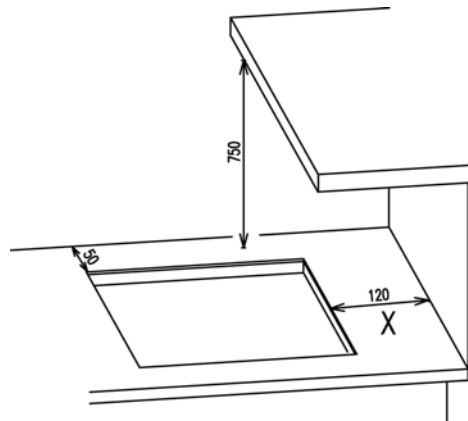

figure 2

5.2 Gas Connection

Connection to the gas mains may be made with a rigid copper pipe or with a flexible pipe conforming to the provisions defined by standard regulations in force.

After connection operations, make sure there is no leakage through the soapy solution.

If the pressure can not be adjusted, use the normal gas pressure to check the leak-tightness.

5.2.1 Connection with rigid copper pipe:

Connect the gas supply and the product with the metal pipe (show in the figure), put the seal ring B to the surface of the joint C, and screw D to gas pipe A.

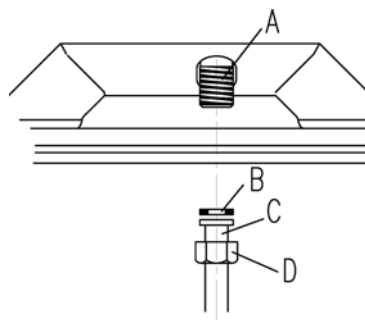

5.2.2 Connection with flexible steel pipe:

The gas supply should be LPG.

The elbow of the appliance and the pressure regulator is fast connectors. Hitch two metal circle E to the two end of the position S. Rotate metal circle E closely to F in order to avoid the flexible tube to be collapsed to make the gas run smoothly, don't let the flexible pipe to collapsed, drew and crushed.

The flexible pipe must be installed so that pipe length does not exceed 2 meters of maximum extension. Make sure that the pipes do not touch any moving parts or become crushed.

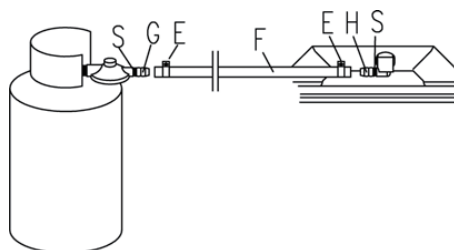

Note:

1. For the newly installed hob or hob not used for some time, it may fail to ignite at first time, because there's air in the tube. You can repeat until the air is exhausted out, then it can be work.

2. When flame is burning on yellow colour, it can be solved by adjusting the value of the air damper. Turn it left or right until the flame turns to blue color.

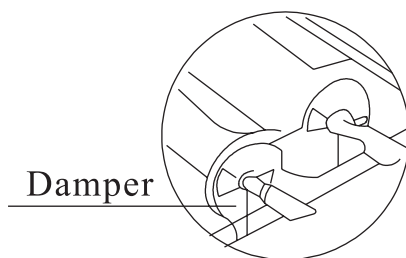

6. INSTRUCCIONES FOR THE USER

6.1 Using the hob



Before lighting the burners, make sure that the flame-spreader crowns and respective caps are properly fitted in their housings. Ensure the flame-spreader holes A are aligned with the ignition plugs and the thermocouples.

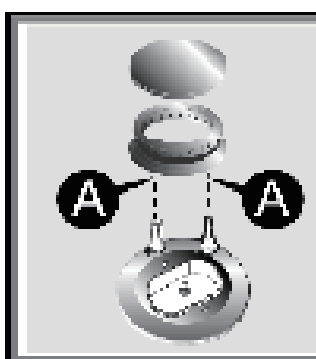

The burner differ in size and power. Choose the most appropriate one for the diameter of the cookware being used.

The burner can be regulated with the corresponding control knob by using one of the following settings:

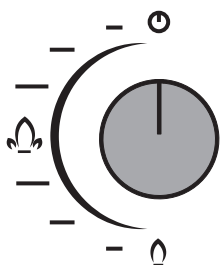

To light the selected burner, first press the corresponding knob down fully, turn it anticlockwise to the max flame symbol and keep the knob pressed for approximately 2-3 seconds to allow the safety device “F” to heat up. The gas can be delivered when the valve is open.

To turn off a burner, turn the knob clockwise until it stops (it should be on the “⊙” setting).

Caution: if the burner accidentally goes out, turn off the gas with the control knob and wait at least 1 minute before you try to light it again.

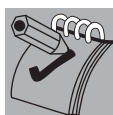

If the burners should go out accidentally a safety device will be tripped about 20 seconds later, cutting off the gas supply even if the gas tap is open. In this case, turn the knob back to the off position and wait at least 60 seconds before trying to re-light the burner.

6.2 Practical hints for using the burners



For better burner efficiency and to minimize gas consumption, use pans with flat, even bottoms with lid and of suitable size for the burner, so that flames do not reach up the sides of the pan (see point “6.3 Pan diameters”). Once the contents come to the boil point, lower the flames so that it does not boil over.

When cooking, to prevent burns or damage to the hob, all pans or griddle plates must be placed inside the perimeter of the hob. Take the greatest care when using fats or oils since they may catch fire if overheated.

6.3 Pan diameters



BURNER'S

ΦMIN. AND MAX. (IN CM)

Big Burner

26 - 28

Small Burner

10 - 14

7. CLEANING AND MAINTENANCE

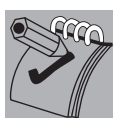

Never use a jet of steam for cleaning the appliance.

7.1 Cleaning the stainless steel surfaces



To keep stainless steel surfaces in good condition, it must be cleaned regularly, after each use of the appliance, first allowing it to cool.

7.1.1 Routine daily cleaning

When cleaning and caring for stainless steel surfaces, always use only specific products which do not contain abrasives or chlorine-based acids.

Instructions for use: pour the product onto a damp cloth and wipe over the surface, then rinse thoroughly and dry with a soft cloth or chamois leather.

7.1.2 Food stains or spills

Never use metal scouring pads or sharp scrapers which will damage the surface. Use ordinary non-abrasive products for steel, with the aid of wooden or plastic utensils if necessary. Rinse thoroughly and dry with a soft cloth or chamois leather.

7.2 Cleaning of cooking hob components

To facilitate cleaning, pan stand grids, caps, flame spreader crowns and burners are all removeable; wash with warm water and non-abrasive detergent, taking care to remove all stubborn food residues. Wait for all parts to be fully drying before remounting. Refit the caps on the respective flame-spreader crowns, making sure that notches A align with burner pins B.

To work well, the ignition pin and thermocouples must always be very clean. Check them frequently and clean them with a wet cloth if necessary. Any dry residue should be removed with a toothpick or a needle.

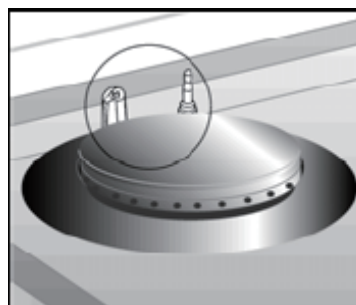
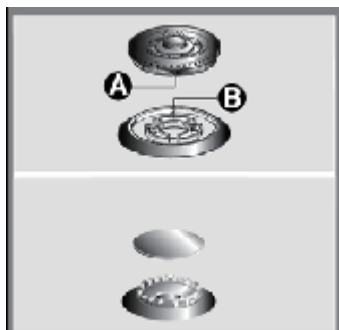

8. TROUBLESHOOTING

Problems	The cause of problem	Settlements for the problems
It won't fire	It is forgotten to open the general gas valve	Firstly turn off the knob, and then open the general gas valve
	Air is mixed into the gas pipe	Ignite repeatedly until the air is absolutely discharged
	The rubber tube bends or flattens	Unfold or change the rubber tube
	Ignition device and insulation point is dirty and damp	Clean it with a dried cloth
	Safety valve doesn't open	Press and turn the knob to intense fire, make sure the hob is fired and keep on pressing for 3 to 4 seconds
	The battery is out of use; the battery doesn't touch well; or the battery is up side down	Change the battery or refix the battery
	There's problem with the ignition device or the ignition pin is not in the right position	Ask the professional maintenance man for maintaining

There is a warning tone when ignition	The battery is low	Change the battery
Gas leak	The rubber tube cracks or breaks	Change the rubber tube
	The rubber tube joint doesn't connect well with rubber tube or other tube	Check the air-tightness of the gas tube and set it properly
Unstable flame	Whether the LPG is used up	Change into a new bottle of LPG
Soft and yellow flame	The throttle is not properly adjusted, and the air is insufficient	Gradually enlarge the throttle until the flame turns normal blue
The flame escapes from the fire hole or flameout is with fulmination	The throttle is not properly adjusted, and the air is insufficient	Gradually enlarge the throttle until the flame turns normal blue
Few flames	Injector or stopcock is jammed	Use a iron wire to dredge the injector or the valve core
The flame isn't in uniform length and the flame is yellow	Fire lid is not properly covered, and there's charcoal other dirt stuffing the fire hole	Make sure that the fire lid is on the right position ; get rid of the dirt in the fire hole
The flame accidentally goes red	Under a certain climate, the gas is with much humidity	The flame turns red because there's calcium in water, so don't be worry about it

9.PRODUCT SPECIFICATION

Model NO.	ETN 78 2G	DRF 73 2G	VCN 73 2G
Rated Voltage	DC 1.5V	DC 1.5V	DC 1.5V
Product Size	780 x 450 x 110mm	730 x 410 x 110mm	730 x 410 x 110mm
Cut out Size	715 x 415mm	630 x 350mm	630 x 350mm
Gas Type	LPG(2.8mBar)	LPG(2.8mBar)	LPG(2.8mBar)
Power	5.0kW + 5.0kW	5.0kW + 5.0kW	4.5kW + 4.5kW

Model No.	BMF73-2G	DMF73-2G	DRF TW75-2G	3D78-2GS
Rated Voltage	DC 1.5V	DC 1.5V	DC 1.5V	DC 1.5V
Product Size	730 x 410 x 110mm	730 x 410 x 110mm	750 x 430 x 110m	780 x 450 x 110mm
Cut out Size	630 x 350mm	630 x 350mm	630 x 350mm	680 x 380mm
Gas Type	LPG(2.8mBar)	LPG(2.8mBar)	LPG(2.8mBar)	LPG(2.8mBar)
Power	5.0kW + 5.0kW	5.0kW + 5.0kW	5.0kW + 5.0kW	5.0kW + 5.0kW

Thiptanaporn Co., Ltd.

46, Soi Bangna-Trat 25, Bangna-Trat Road, Bangna, Bangkok, 10260, Thailand

Contact: 02-3619035-42, Website: www.thiptanaporn.com, Email: sales@thiptanaporn.com